

TW700Ti-CR

Professional Super Tweeter



KEY FEATURES

- 1.5" Voice coil
- 240 Watts continuous program power
- 107 dB Sensitivity
- Double Magnet
- High grade Titanium Diaphragm

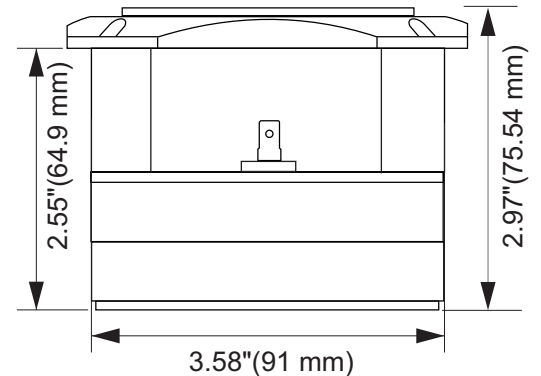
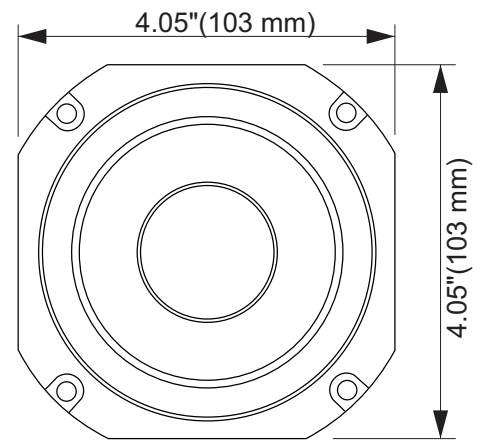

GENERAL SPECIFICATIONS

Nominal Impedance	8 Ohm
Nominal Power Handling	120 Watts
Continuous Program Power(RMS)	240 Watts
Max Peak Power	480 Watts
Sensitivity 2.83V at 1m*	107 dB
Recommended High Pass Crossover**	5000 Hz***
for Full Power Handling	*12db/oct Crossover
Frequency Response at -10dB	3,500-20,000Hz
Voice Coil Diameter	1.5" (38 mm)
Voice Coil Wire	CCAW
Voice Coil Former Material	Kapton®
Diaphragm Material	Titanium
Flux Density	1.60 T
Magnet Material	Ferrite

EXTRA INFO

Overall Depth	2.97" (75.54 mm)
Mounting Depth	2.55" (64.9 mm)
Overall Width	4.05" (103 mm)
Overall Height	4.05" (103 mm)
Cutout Diameter	3.58" (91 mm)
Net Weight	3.58 lbs (1.58 kg)
Shipping Weight (pair)	3.62 lbs (1.64 kg)
Carton Dimensions W x L x H	4.5" x 4.5" x 3.25" (114 x 114 x 82.5 mm)

Impedance Curve - Free Air

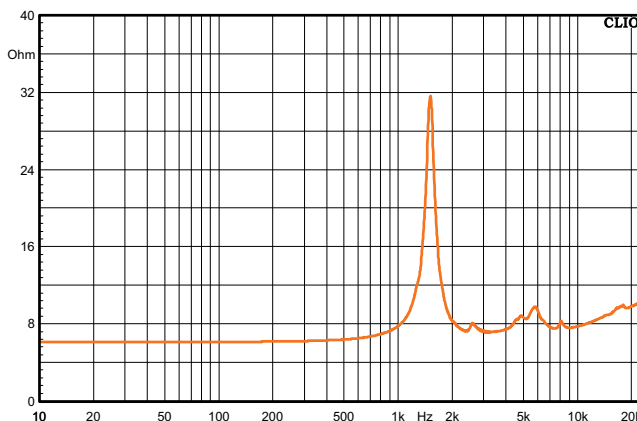

Frequency Response Measured at 2.83V/1m

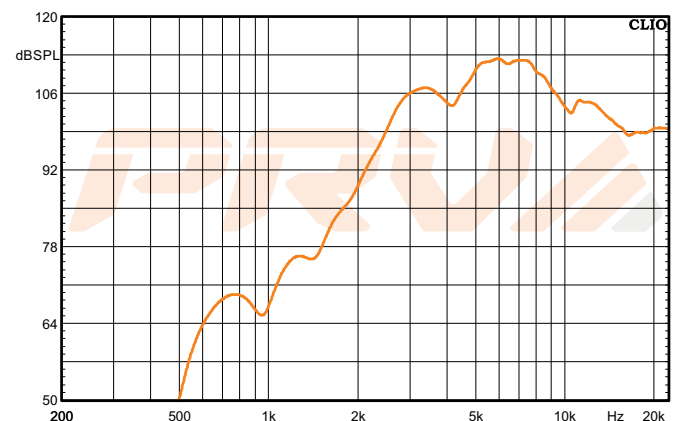

PRVA AUDIO USA (USA and Export)
FORT LAUDERDALE, FL
support@prvaudio.com
www.prvaudio.com