

# MT6CX580-NDY-4

Professional Coaxial Driver



## KEY FEATURES

- 2.0" / 1/4" Voice coil
- 600 / 80 Watts continuous program power
- 95 / 106 dB Sensitivity



GENERAL SPECIFICATIONS

	Low Freq.	High Freq.
Nominal and Throat Diameter	6.5"(152mm)	1"(25.4mm)
Nominal impedance	4 Ohm	8 Ohm
<b>Nominal Power Handling</b>	<b>300 Watt</b>	<b>40 Watt</b>
Continuous Program Power (RMS)	500 Watt	80 Watt
Max Peak Power	1200 Watt	160 Watt
<b>Sensitivity 2.00V at 1m</b>	<b>95 dB</b>	<b>106 dB</b>
Recommended Hi Pass Crossover*	105 Hz*	1800 Hz*
<small>*For Full Power Handling</small>	<small>*12db/oct Crossover</small>	<small>*12db/oct Crossover</small>
<b>Frequency Response</b>	<b>100-10kHz</b>	<b>1.3-20kHz</b>
Voice Coil Diameter	2"(51 mm)	1.75"(44mm)
Voice Coil Wire	CCAW	CCAW
Voice Coil Winding Depth	11.0 mm	N/A
Former Material	Kapton	Kapton
Magnetic Gap Depth	8.0 mm	N/A
Frame and Diaphragm Material	Aluminum	Titanium

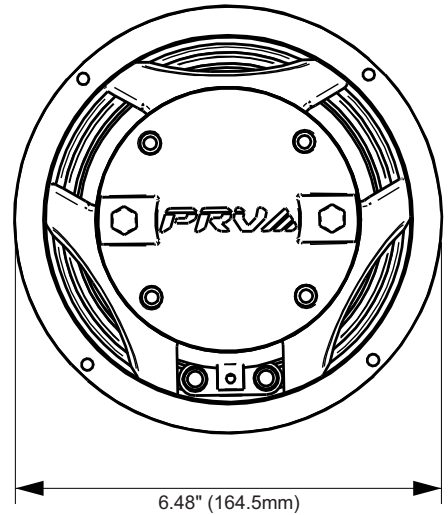

THIELE-SMALL PARAMETERS

Equivalent Volume	Vas	5.77 l
Excursion (mathematical)***	Xmax	3.50 mm
Free Air Resonance	Fs	105.9 Hz
Mechanical Factor	Qms	8.54
Electrical Factor	Qes	0.43
Total Factor	Qts	0.41
Cone Area	Sd	143 cm <sup>2</sup>
Mechanical Mass	Mms	11.19 g
Bl Factor	BL	7.16 Tm
Dc Resistance	Re	3.0 Ohm
Inductance	Le	0.178 mH at 1 kHz
Mechanical Mass Without Air	Mmd	10.33 g
Mechanical Compliance	Cms	0.202 mm/N

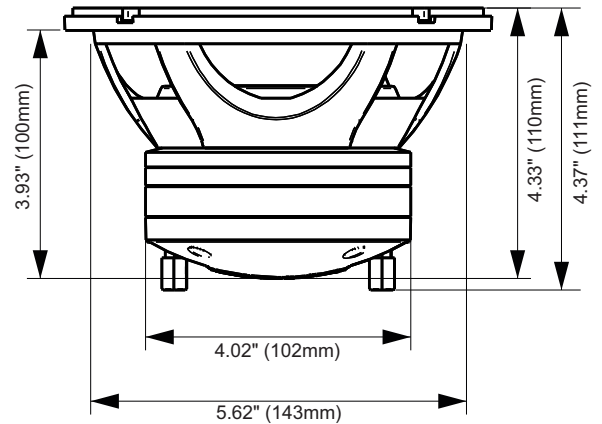

EXTRA INFO

Overall Diameter	6.48" (164.5 mm)
Front Mount Baffle Cutout	5.62" (143 mm)
Mounting Depth	3.93" (100 mm)
Overall Depth	4.37" (111 mm)
Net Weight	4.18 Lbs (1.9 kg)
Shipping Weight	4.62 Lbs (2.1 kg)
Carton Dimensions W x L x H	7.6"x 7.0" x 5.12" (193 x 178 x 130mm)

Impedance Curve - Free Air

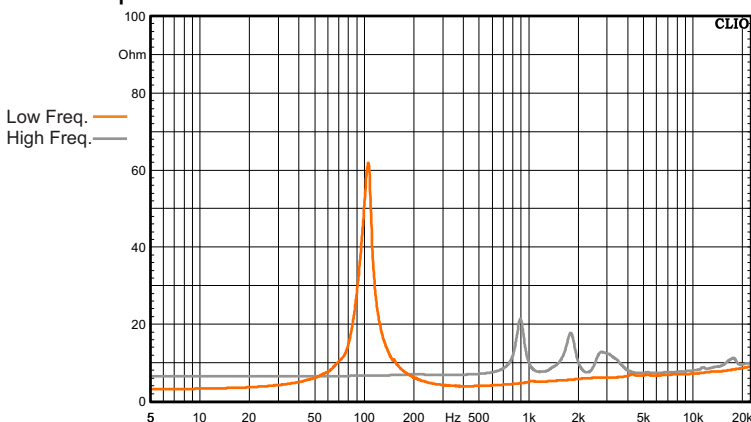

Frequency Response Measured at 2.00V/1m

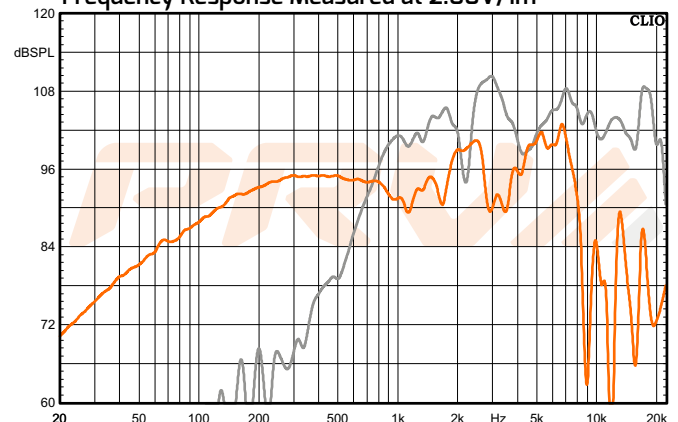

\*\*Xmax=(Voice coil winding depth-Magnetic Gap depth)/2+ Magnetic Gap Depth/4  
 \*\*\* T-S parameters measured after 2 hours at 1/2 Rated power, pink noise preconditioning test

PRVA AUDIO USA (USA and Export)  
 POMPANO BEACH, FL  
 support@prvaudio.com  
 www.prvaudio.com